

**QUALITY
SUSTAINABILITY
VERSATILITY
DURABILITY
RESILIENCY**



**PRECAST
STAIRS**

Why choose Diamond Precast for your project?

Benefits of precast concrete stairs

- Cost effective
- Ease and speed of install
- Immediate access for all trades
- Low environmental impact
- Variety of customizable options for color, size, finish, and nosings
- Use with wood or steel supports
- Long service life
- Low maintenance costs
- Weatherproof
- Versatile, for use in apartments, condos, medical office buildings, high-rises, commercial and residential structures
- Ship all over the Western U.S.

Website:

www.diamondprecaststairs.com

Email:

diamondconcreteproducts@gmail.com

Diamond Concrete Products LLC

Diamond Precast Stairs

19405 63rd Ave NE, Arlington, WA 98223

Tel: 360-435-6151 Fax: 360-435-6036



Diamond Precast Stairs has been manufacturing architectural precast concrete pieces, in northwestern Washington State, for decades.

We are able to fabricate thousands of custom and standard stair treads for apartment complexes, mixed use projects and commercial buildings, yet also are able to produce once off pieces for custom projects. We work with a broad customer base, including general contractors, framers, steel fabricators, property managers, and residential home owners.

Precast concrete has numerous advantages, which include:

- Precast concrete arrives ready and easy to install, saves time and labor costs, and minimizes concrete pouring and finishing on site.
- Fast installation and no curing time on site allows less job site disruption, and other trades can start work sooner.
- Concrete is a durable material, weatherproof and has a long service-life.
- Precast offers almost limitless options in the variety of products and design options, including finish, color, size, and shape.
- Products are engineered, and manufactured in an environment which ensures quality, uniformity, fit, durability, function and precise workmanship.
- Sustainability - the production of precast is environmentally responsible, using our local sources for materials, and supplying a product that outlasts other materials.

We look forward to helping you complete your project!

OPEN RISER STAIR TREADS (FLATS)

Open Riser (Flat) Stair Treads are manufactured to detailed industry standards. Treads narrower than 48" wide are 2 ½" thick as standard, and 3" thick for treads 48" wide and longer.

Each tread includes installation hardware (two brackets, lag bolts and hex bolts).

Designed with cost in mind, the basic open riser tread is functional yet visually pleasing.

Treads can be manufactured to spec and code realizing architectural and aesthetic goals.

Finishes and customizations available include:

- Broom finish
- Broom finish with 2" exposed aggregate strip
- Exposed aggregate finish
- Smooth trowel finish
- Polished finish
- Sandblast finish
- Aluminum Nosings & Luminescent Safety nosings
- Colored concrete - see www.daviscolors.com for concrete colors available

Standard Dimensions and Approximate Weights for Open Riser Treads:

36" x 12" x 2.5" - 97lbs.

38" x 12" x 2.5" - 101lbs.

40" x 12" x 2.5" - 103lbs.

42" x 12" x 2.5" - 112lbs.

44" x 12" x 2.5" - 121lbs.

48" x 12" x 2.5" - 128lbs.

54" x 12" x 3" - 150lbs.

60" x 12" x 3" - 165lbs.

72" x 12" x 3" - 180lbs

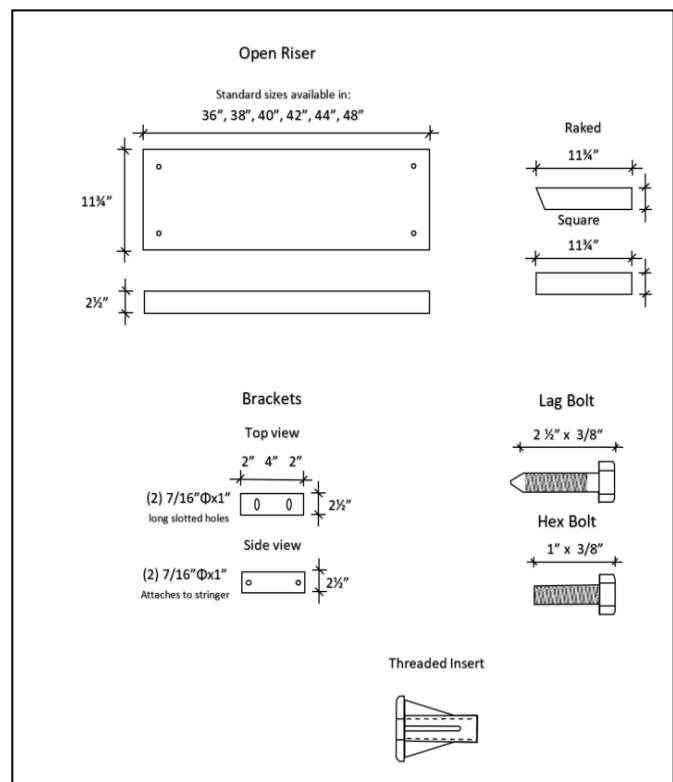

HALF RISER STAIR TREADS (4" RISER)

Half Riser Stair Treads are manufactured to detailed industry standards. All lengths of half riser treads are 2½" thick.

Each tread includes installation hardware (two brackets, lag bolts and hex bolts).

Designed with cost in mind, the basic half riser tread is functional yet visually pleasing, and is manufactured to spec and code, realizing both architectural and aesthetic goals.

Finishes and customizations available include:

- Broom finish
- Broom finish with 2" exposed aggregate strip
- Exposed aggregate finish
- Smooth trowel finish
- Polished finish
- Sandblast finish
- Aluminum Nosings & Luminescent Safety nosings
- Colored concrete - see www.daviscolors.com for concrete colors available

Standard Dimensions and Approximate Weights for Half Riser Treads

36" x 12" x 4" – 110lbs.

38" x 12" x 4" - 115lbs.

40" x 12" x 4" - 120lbs.

42" x 12" x 4" – 125lbs

44" x 12" x 4" - 133lbs.

48" x 12" x 4" – 142lbs

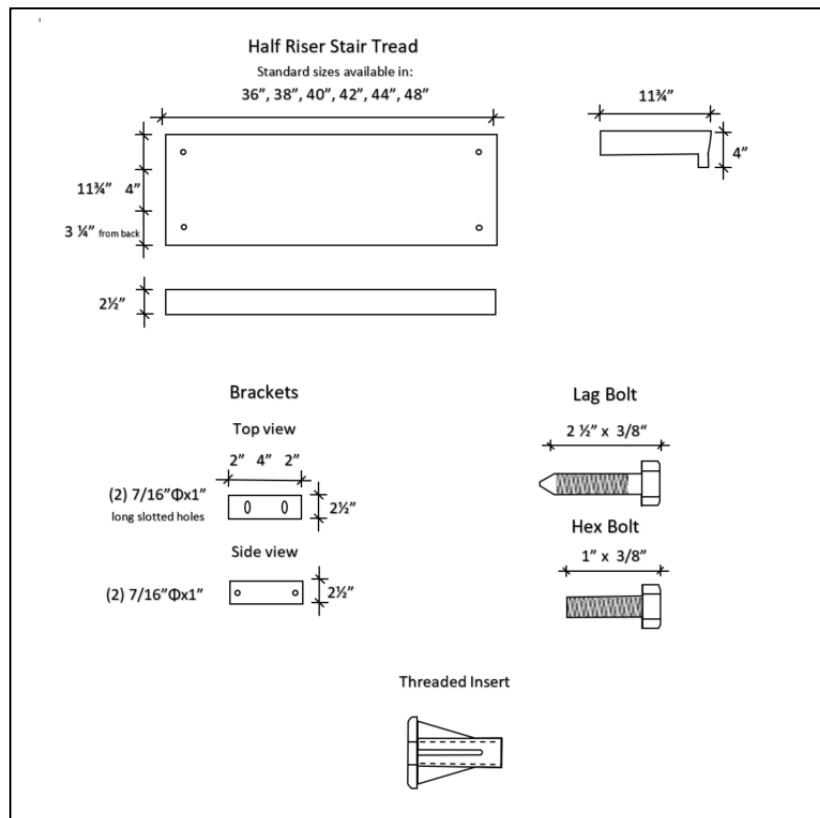

CLOSED RISER STAIR TREADS (7" RISER)

Closed Riser Stair Treads are manufactured to detailed industry standards. Treads narrower than 48" wide are 2½" thick as standard, and 3" thick for treads 48" wide and longer.

Each tread includes installation hardware (two brackets, lag bolts and hex bolts).

Closed riser treads are functional, manufactured to spec and code, and succeed in realizing architectural and aesthetic goals.

Finishes and customizations available include:

- Broom finish
- Broom finish with 2" exposed aggregate strip
- Exposed aggregate finish
- Smooth trowel finish
- Polished finish
- Sandblast finish
- Aluminum Nosings & Luminescent Safety nosings
- Colored concrete - see www.daviscolors.com for concrete colors available

Standard Dimensions and Approximate Weights for Closed Riser Stair Treads

36" x 12" x 7" - 115lbs.

38" x 12" x 7" - 124lbs.

40" x 12" x 7" - 129lbs.

42" x 12" x 7" - 135lbs.

44" x 12" x 7" - 142lbs.

48" x 12" x 7" - 152lbs.

54" x 12" x 7" - 177lbs

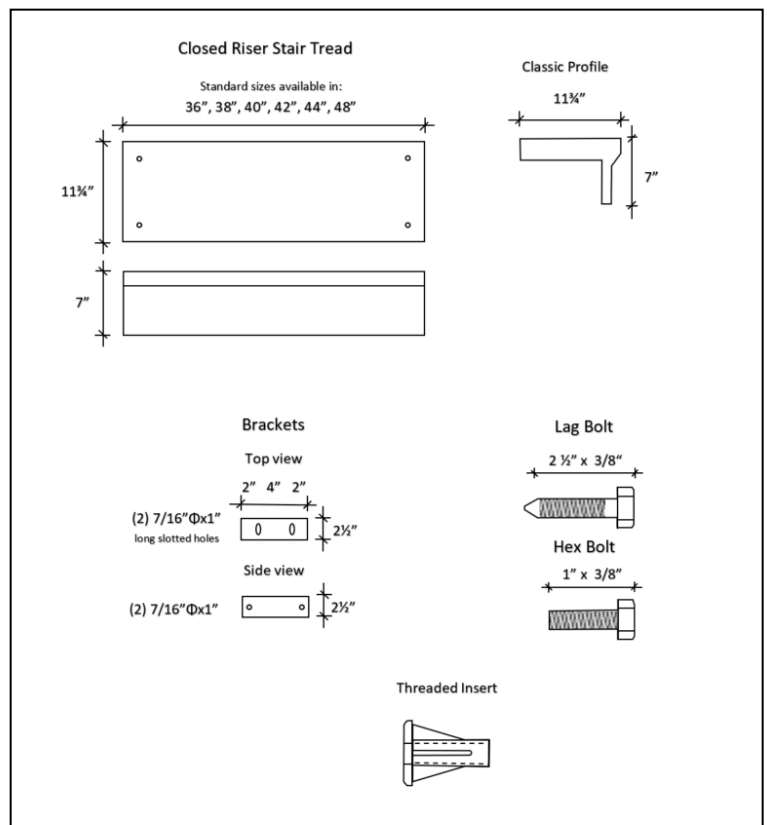

CANTILEVER STAIRS

Cantilever Stair Treads are supported by a single 4" or 6" OD beam. Weld plates for railing attachment are optional.

Installation is designed to be a simple. Treads are attached to a single stringer, available in closed or open riser style, and they are independent of building structure.

Finishes and customizations available include:

- Broom finish
- Broom finish with 2" exposed aggregate strip
- Exposed aggregate finish
- Smooth trowel finish
- Polished finish
- Sandblast finish
- Aluminum Nosings & Luminescent Safety nosings
- Colored concrete - see www.daviscolors.com for concrete colors available

Standard Dimensions and Weights

36" x 12" - 120lbs.

42" x 12" - 127lbs.

44" x 12" - 139lbs.

48" x 12" - 155lbs.



INSTALLATION INSTRUCTIONS & TIPS

Before Installing Precast Stair Treads

Diamond Precast Stair treads are manufactured for compliance with industry standards and job specifications. Diamond Precast Stair treads are cured for a minimum of 5-7 days prior to shipping and are wrapped and banded with special care for shipping to our clients. In spite of this, during the process of unloading, handling at the jobsite and installation the treads can be chipped and/or damaged and may require field repair or replacement. Upon delivery of the precast stair treads it is the installer's duty to examine each tread for damage and to contact the Diamond Precast Stairs for recommendations regarding field repair or replacement. Diamond Precast Stairs is not responsible for improper installation of stair treads, damage from abuse or neglect while unloading, mishandling, or poor jobsite storage conditions.

Stair Tread Installation

The installer must comply with proper field storage, handling, installation and permanent bracing, anchoring, connections and field assembly requirements. It is recommended that installation is completed by an experienced and responsible person with stair tread installation experience for the size and type of stair being installed. Correct installation is a serious matter for both proper performance of the product and safety. Proper installation which includes proper handling, placement and tightening of the bolts is absolutely critical to proper product performance.

Installing stair treads is a 2-person job, treads are heavy and difficult to handle.

Install brackets - attach to stringer, either with lag bolts, or by welding.

Place stair treads on top of bracket and insert machine bolts into the insert through the bracket.

Never over tighten the machine bolts, it can lead to stripping of the insert.

Stair Tread Care

The installer must take extreme care when unloading and handling treads. Stair treads should be stored in a manner that they will not be damaged and discolored from jobsite conditions such as heavy equipment operations, painting, stacking materials on or against stair treads. The installer should avoid damage to stair treads from dragging equipment, dollies, appliances, furniture, etc over the treads being installed.

CARE & MAINTENANCE

Care and Maintenance of Stair Treads

Precast treads can be rinsed off with soap and water using a terry cloth. For stubborn dirt, a broom can be used to brush dirt while spraying with a garden hose. A commercial stain remover may also be used – use product as directed. Sealing the concrete treads with a natural look/matte finish sealer will protect the treads from staining. A high gloss sealer applied by brush will give the concrete a wet-look, and will provide adequate protection from staining.

The application of deicing chemicals and salt can result in the deterioration and spalling of concrete stair treads, due to chemical damage, and repeated concrete exposure to freezing and thawing cycles. Avoid extended and repeated use of deicers and salt.

Warranty Information

All concrete products manufactured by Diamond Concrete Products LLC are warranted against defects in material and/or workmanship for a period of two years from the date of shipping.

Upon inspection, Diamond Concrete Products LLC will supply, only, the defective parts to the original purchaser. Diamond Concrete Products LLC agrees to repair or replace at no charge any part, parts, or complete unit found to be defective within this period. Diamond Concrete Products LLC will not be responsible for painting, shipping, transportation, labor, and/or field service charges. No warranty is expressed or implied for merchantability or suitability for particular applications of purposes either determined by the purchaser or not. No other warranties are expressed or implied by Diamond Concrete Products LLC, nor shall they extend beyond stated time period.

Grinding, cutting, drilling, painting, staining, sandblasting or other alterations not performed by Diamond Concrete Products LLC will void product warranty or replacement. Extended and repeated use of deicers, salt and other chemicals will damage product and void warranty.

Diamond Concrete Products LLC reserves the sole right to determine whether the defect is a result of product failure or abuse to the product. All concrete products must be properly protected from damage and properly stored until installed.

Shipments of Material and Hardware must be inspected at time of delivery. Any defects or inaccuracy of shipment must be reported within 15 days of shipment for warranty replacement.

This warranty shall be void if visible evidence indicates that recommended installation procedures and storage instructions were not followed

CONCRETE FINISHES AND COLOR

Once your precast project needs have been narrowed by style and size, there are a wide variety of finishes, concrete colors and nosings available to meet your exact project specifications.

Most products can be ordered with a broom, exposed aggregate, smooth trowel, sandblast, or polished finish.

Aluminum, abrasive and luminescent safety nosings are also available to add to some products, which aid in meeting ADA standards and safety requirements. Some may be added to products after production (by purchaser), and some maybe be cast into the concrete during production. Different options are available from Balco, Wooster, and Nystrom.

Davis Colors offers a wide selection of concrete pigments to add concrete coloring and enhance precast products. A sample chart is shown below. More detailed information and color sample tiles can be found at their website: www.daviscolors.com.

Adobe 61078	Autumn Gold 5844	Baja Red 160	Bayou 6130	Brick Red 160	Canyon 160	Caramel 6455
Cliffside Brown 6804	Cobblestone 860	Cocoa 6130	Dark Gray (Carbon) *8084	Dark Gray (Iron Oxide) 860	Dune 6058	Eastern Tan 61222
Euroblue (Cobalt) 418	Flagstone Brown 641	Granite Red 1395	Graphite (Carbon) *8084	Graphite (Iron Oxide) 860	Green Slate 3685	Harvest Gold 5084
Jet Black (Carbon) *8084	Jet Black (Iron Oxide) 860	Kailua 677	Lakeside Brown 6804	Light Gray (Carbon) *8084	Light Gray (Iron Oxide) 860	Mesa Buff 5447
Mesquite 677	Miami Buff 5447	Mocha 6058	Omaha Tan 5084	Outback 677	Padre Brown 61078	Palomino 5447
Pebble 641	Pewter 860	Plum 1395	Pueblo Brown 61078	Roadside Brown 6804	Rustic Brown 6058	Salmon 10134
San Diego Buff 5237	Sandstone 5237	Sangria 1117	Santa Fe 1117	Sequoia Sand 641	Sierra 61078	Silversmoke (Carbon) *8084
Silversmoke (Iron Oxide) 860	Southern Blush 10134	Spanish Gold 5084	Sunset Rose 160	Taupe 677	Terra Cotta 10134	Tile Red 1117
Willow Green 5376	Western Gold 5844	Yosemite Brown 641				



Print the form below to provide the information we need to quote your project.

Or email your project details to: diamondconcreteproducts@gmail.com

Quote Request Form

Date:

Company Name:

Contact:

Phone:

Fax:

Email:

Steps required to determine tread size:

1. Determine inside stringer to stringer dimension minus 1/4" for installation.
2. Determine location of anchors – outside edge to anchor center.
3. Measure from front edge to center of front insert
4. Measure center to center for insert location
5. Measure thickness of tread

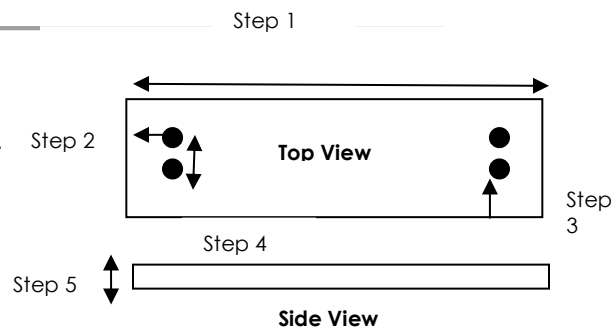

Shipping Address:

Size and Style of Tread:

Quantity Needed:

Finish of Tread:

Forklift on Delivery Site: YES or NO

Comments:

